

# Berkshire XLT



## FREIGHTLINER® XCR CHASSIS WITH TRU-BRACE FOUNDATION

- + Cummins ISL Turbo Diesel 8.9 Liters 450 HP, 1250 LB/FT of Torque
- + Allison 3000MH 6-Speed Transmission
- + Trailer Hitch with 15,000 LBS. Capacity
- + Independent Front Suspension
- + V-Ride Rear Suspension 
- + Ultra Steer TAG Axle w/Passive Steer Technology 
- + Mobile Eye Collision Mitigation
- + TPMS-Tire Pressure Monitoring System
- + 150 Gallon, Locking, Dual Fill Fuel Tank
- + 15 Gallon Def Tank

## BERKSHIRE XLT FEATURES

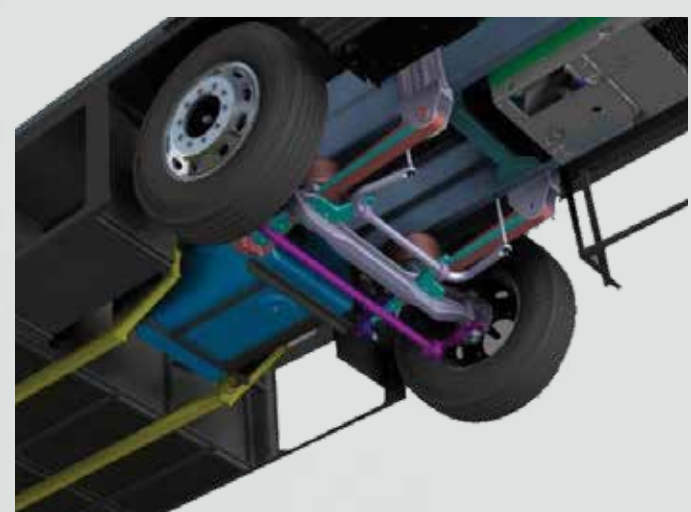

**TRU-BRACE**  
ANTI-CAMBER SUPPORT BRACING



**3 1/8" THICK FLOOR**  
INCREASES RIDE QUALITY, REDUCE ROAD NOISE, ADDED RIGIDITY TO THE FOUNDATION

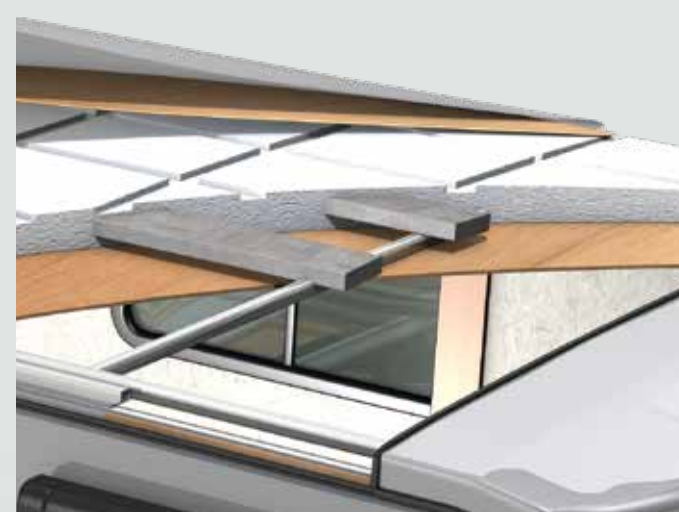

**5 1/4" THICK ROOF**  
CROWNED ONE PIECE FIBERGLASS ROOF



**NOBLE SELECT**  
PREMIUM COMPOSITE, HIGH GLOSS SIDEWALLS. IMPERVIOUS TO WATER, RESISTANT TO THE ELEMENTS & IMPACT, PUNCTURE RESISTANT.



**HOUSE BATTERIES**  
(6) SIX VOLT DEEP CYCLE HOUSE BATTERIES



**2800 WATT INVERTER**  
2800W PURE SINE WAVE INVERTER WITH 125 AMP CHARGER



**WATER MANIFOLD SYSTEM**  
OFFERING POINT TO POINT CONNECTIONS, EQUALIZED WATER PRESSURE AND TEMPERATURE, AND THE ABILITY TO ISOLATE ANY ISSUE



**AQUA HOT HYDRONIC HEAT**  
PROVIDES EVEN HEATING THROUGHOUT THE COACH, ALONG WITH INSTANT HOT WATER, WHILE ALSO MAKING THIS COACH AN ALL ELECTRIC COACH



**SHOWER MISER SYSTEM**  
EXTENDED STAY TECHNOLOGY HELPS INCREASE GRAY WATER TANK CAPACITY WHEN DRY CAMPING



**PASSENGER WORK STATION**  
STOW AWAY PASSENGER SIDE WORK TABLE



**WIRELESS PHONE CHARGE**  
DRIVER CONSOLE INDUCTION CHARGER



**MULTIPLEX CONTROL**  
PRECISION CIRCUITS MULTIPLEX SYSTEM WITH PRECISION PLEX APP



**GOLD HEAT® HEATED FLOORS**  
ELECTRIC HEATED FLOORS THROUGHOUT THE COACH

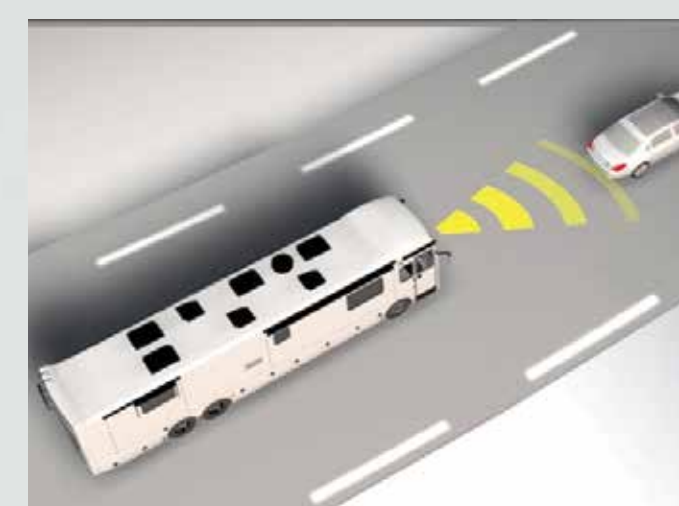

**MOBILE EYE COLLISION MITIGATION**  
FORWARD COLLISION WARNING, LANE DEPARTURE WARNING, PEDESTRIAN COLLISION WARNING, HEADWAY MONITORING, & SPEED LIMIT INDICATOR

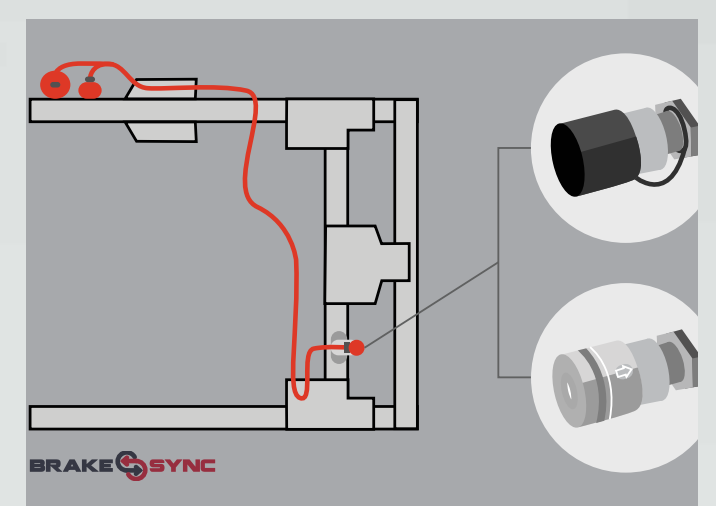

**BRAKE SYNC**  
CONTINUOUS INNOVATION IN SAFETY SYSTEMS. FACTORY-WARRANTED SUPPLEMENTAL BRAKING SYSTEM

### 45A

7 = Standard 7  
8 = Optional 9

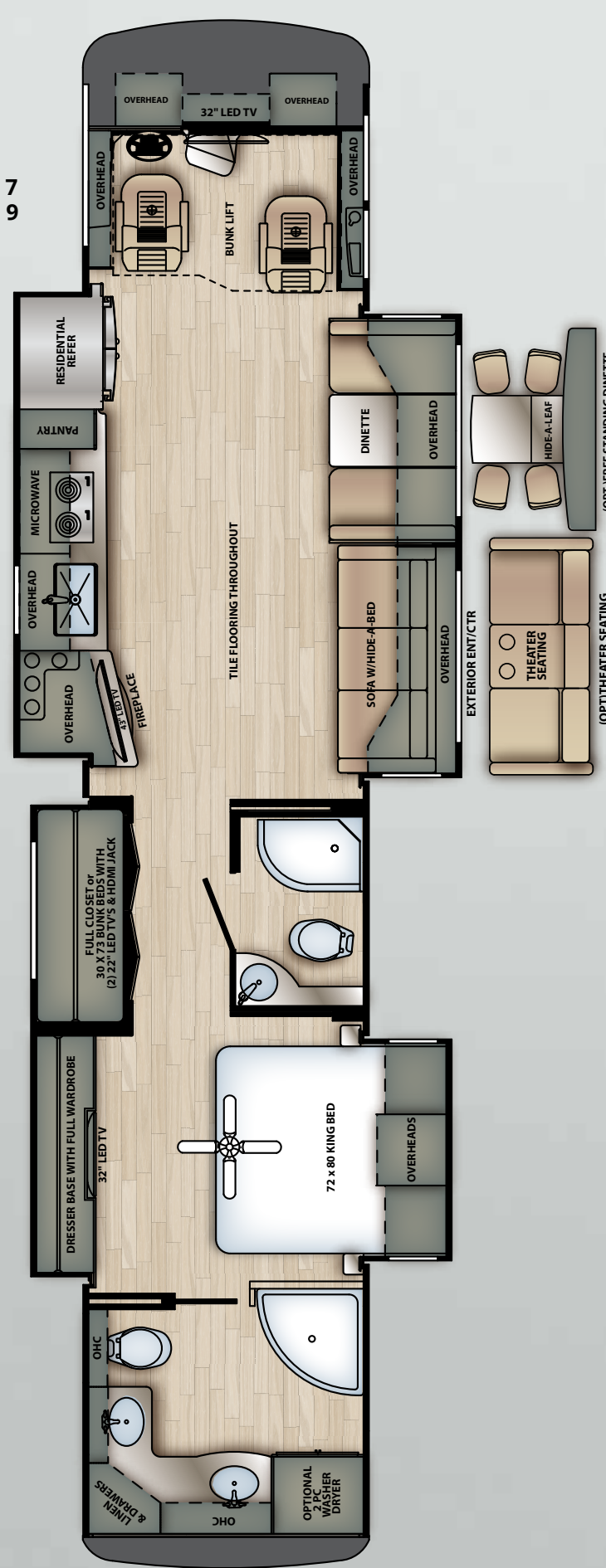

### 45E

9 = Standard 6  
8 = Optional 8



### 45CA

9 = Standard 8  
10 = Optional 10

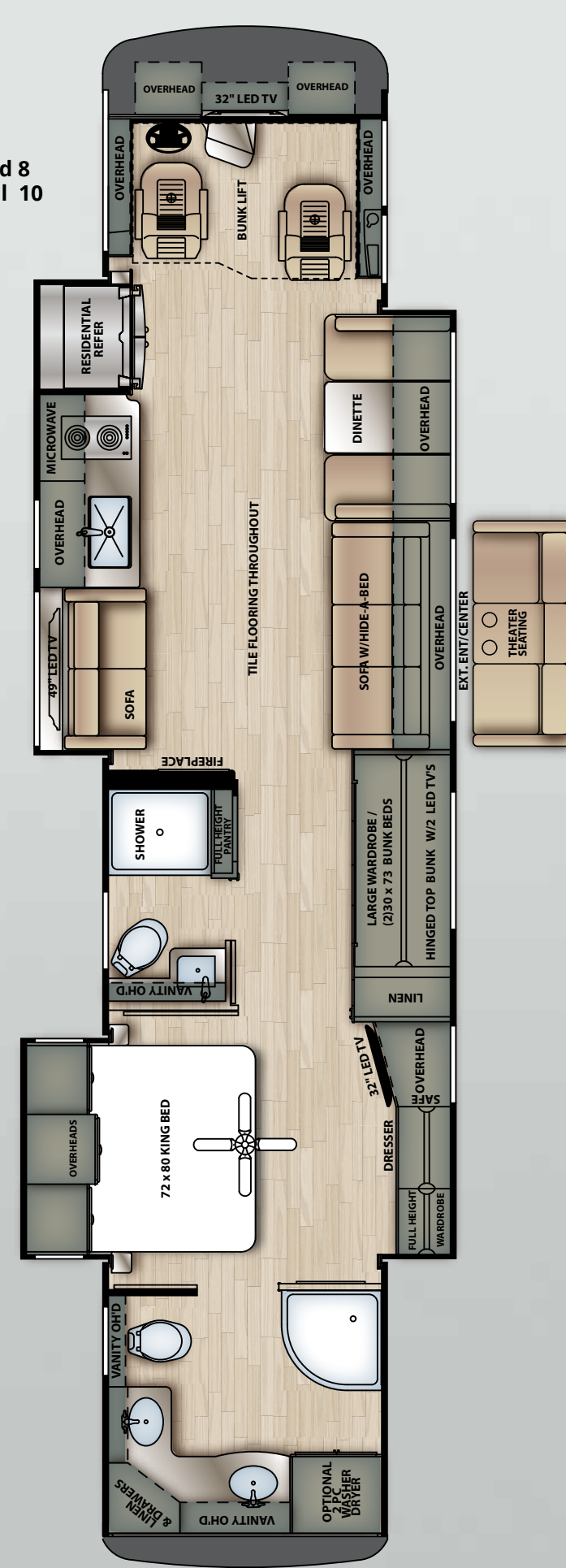

### CONVENIENCE STANDARD PACKAGE FEATURES



### STANDARD & OPTIONAL FEATURES

- + 3 Door Residential Refrigerator
- + Hardwood Cabinetry throughout the Coach
- + Drop Down Euroloft Cab Over Bunk, 500 Lbs Capacity
- + Solid Surface Countertops With Lighted Edge In Kitchen
- + BASF Full Body Paint with 4x the Clear Coat
- + Diamond Shield Front Mask Protective Film
- + Central Vacuum System
- + Bedroom Ceiling Fan
- + Smart TVs Throughout (Excluding Bunk TVs)
- + High Definition Cat6 Matrix Signal Distribution
- + JBL Sound Bar w/Integrated Sub & Bluetooth
- + High End Ultraleather® Furniture Material
- + Three 15K BTU Low Profile Air Conditioners (Front And Rear with Heat Pumps)
- + 10" Dash radio w/ color back-up and side view camera pkg with Navigation & Apple CarPlay™
- + Carefree Latitude Dual Pitch Awning With LED Light & Wind Sensor
- + Electronic Safe
- + Heated Floors Throughout
- + 30" Wide Entry Way, With True Diesel Motorhome Entry Door
- + Slide Tray In Basement Storage Compartment
- + Variable 4 GPM Water Pump
- + Electric Fireplace In Living Room
- + Heated Holding Tanks w/Forced Air Duct From Aqua Hot
- + Day/Night Roller Shades Throughout The Coach
- + Optional Stackable Washer And Dryer
- + Optional Power Theater Seating
- + Optional Winegard HD Traveler Satellite System
- + Optional Stainless Steel Dishwasher
- + Optional Basement Pull Out Freezer



Scan the QR Code to learn more about Berkshire Motorhomes.

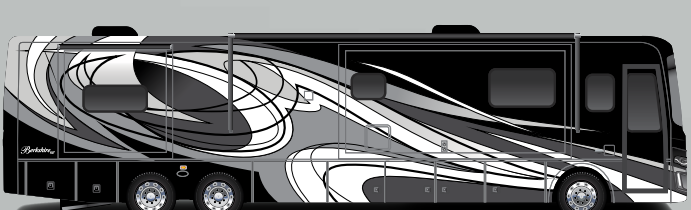

SMOKEY GREY

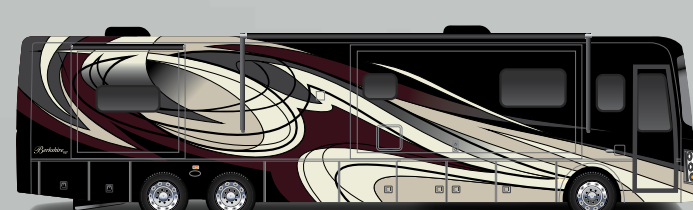

CRIMSON RED

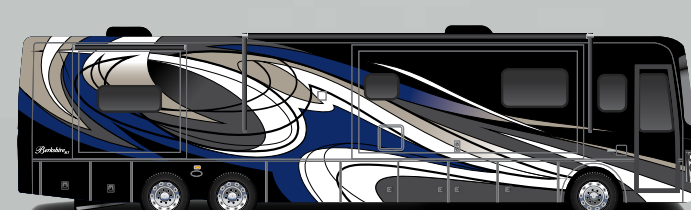

MALIBU

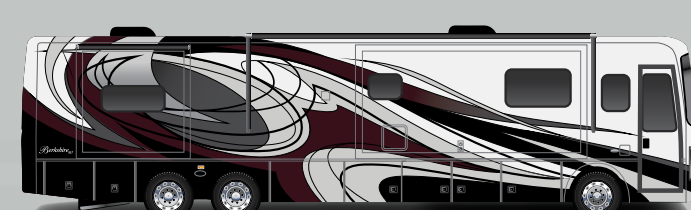

SCARLET RED

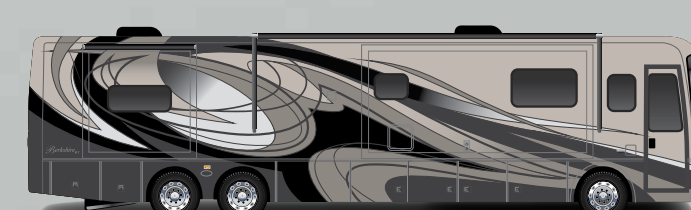

CANTERBURY

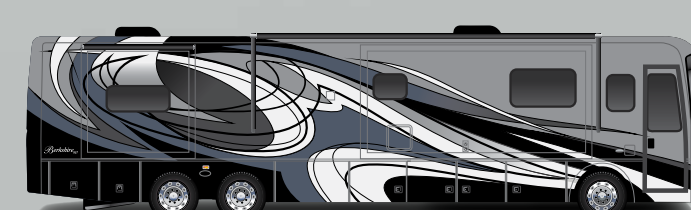

OCEAN VIEW