

Instructions for use

WASHING MACHINE

NA

English, 1

ARXL 129 W SP

Contents

Important safety instructions 2-3

Important safety instructions
Grounding Instructions
Safety

Installation instructions 4-5-6

Unpacking and leveling
Minimum Installation Spacing
Connecting Water Inlet
Drainage
Connecting the drain hose
Electrical
Under Sink Method
Technical data

Description of the washing machine and starting a wash cycle 7-8

Control panel
Indicator lights
Starting a wash cycle

Wash cycles 9

Table of wash cycles
Special wash cycles

Personalization 10-11

Setting the temperature
Setting the spin speed
Functions

Detergents and laundry 12

Detergent dispenser drawer
Bleach cycle
Preparing the laundry
Garments requiring special care
Load balancing system
Helpful Hints

Care and maintenance instructions 13

Cutting off the water and electricity supplies
Cleaning the washing machine
Cleaning the detergent dispenser drawer
Caring for the door and drum of your appliance
Cleaning the pump
Checking the water inlet hose

Troubleshooting 14

Service 15

Warranty, 16-17

NA

 **ARISTON**

Important safety instructions

NA

IMPORTANT SAFETY INSTRUCTIONS

WARNING - To reduce the risk of fire, electrical shock, or injury to persons when using your appliance, follow basic precautions, including the following:

- Read all instructions before using the appliance.
- Do not wash articles that have been previously cleaned in, washed in, soaked in, or spotted with gasoline, dry cleaning solvents, other flammable, or explosive substances as they give off vapors that could ignite or explode.
- Do not allow children to play on or in the appliance. Close supervision of children is necessary when the appliance is used near children.
- Before the appliance is removed from service or discarded, remove the door to the washing compartment.
- Do not add gasoline, dry cleaning solvents, or other flammable or explosive substances to the wash water. These substances give off vapors that could ignite or explode.
- Do not install or store this appliance where it will be exposed to the weather.
- Do not tamper with controls.
- Under certain conditions Hydrogen gas may be produced in a hot water system that has not been used for 2 weeks or more. **HYDROGEN GAS IS EXPLOSIVE.** If the hot water system has not been used for such a period, before using the appliance, turn on all hot water faucets and let the water flow from each for several minutes. This will release any accumulated hydrogen gas. As the gas is flammable do not smoke or use an open flame during this time.
- Turn off water faucets to relieve pressure on hoses and valves and to minimize leakage if a break or rupture occurs.
- Do not reach into the appliance if the tub or drum is moving.
- Do not repair or replace any part of the appliance or attempt any servicing unless specifically recommended in the user-maintenance instructions or in published user-repair instructions that you understand and have the skills to carry out.
- Good, safe practices and caution **MUST** be applied when installing, operating, and maintaining any appliance. Follow basic precaution.
- Disconnect power to the washer at the circuit breaker or fuse box, or unplug the machine in an emergency or when servicing required. Have the installer show you and label the proper switch or fuse at the electrical disconnect box.
- The interior of the appliance should be cleaned periodically by qualified service personnel.
- Before loading the washer, make sure the drum is empty.

SAVE THESE INSTRUCTIONS

GROUNDING INSTRUCTIONS

This appliance must be grounded. In the event of malfunction or breakdown, grounding will reduce the risk of electric shock by providing a path of least resistance for electric current. This appliance is equipped with a cord having an equipment-grounding conductor and a grounding plug. The plug must be plugged into an appropriate outlet that is properly installed and grounded in accordance with all local codes and ordinances.

WARNING - Improper connection of the equipment-grounding conductor can result in a electric shock.

Check with a qualified electrician or service representative or personnel if you are in doubt as to whether the appliance is properly grounded.

Do not modify the plug provided with the appliance: if it will not fit outlet, have a proper outlet installed by a qualified electrician.

Safety



**CAUTION RISK
OF ELECTRIC
SHOCK DO
NOT OPEN**



CAUTION:

To reduce the risk of electric shock, DO NOT remove cover (or back)/no user servicable parts inside. Refer for servicing to qualified services personnel.

The model and serial number of this product can be found inside the door and on the back of the unit.

You should note the model and serial numbers of this unit in the space provided. Retain this booklet as a permanent record of your purchase to aid in identification in the event of theft.

MODEL N. _____

SERIAL N. _____



WARNING:

TO PREVENT FIRE OR SHOCK HAZARD DO NOT EXPOSE THIS PRODUCT TO RAIN OR MOISTURE.



The lightning flash with arrowhead symbol, within an equilateral triangle, is intended to alert the user to the presence of uninsulated “dangerous voltage” within the product’s enclosure that may be of sufficient magnitude to constitute a risk of electric shock to persons.



The exclamation point within an equilateral triangle is intended to alert the user to the presence of important operating and maintenance (servicing) instructions in the booklet.

Indesit Company offers their customers products with the ENERGY STAR Label.

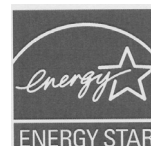

This appliance was tested by UL and conforms with both Canadian and U.S. UL safety requirements and displays their Mark



Installation instructions

NA

! This instruction manual should be kept in a safe place for future reference. If the washer is sold, transferred or moved, make sure that the instruction manual remains with the machine so that the new owner is able to familiarize himself/herself with its operation and features.

! Read these instructions carefully: they contain vital information relating to the safe installation and operation of the appliance.

Unpacking and levelling

Unpacking

1. Remove the washer from its packaging.
2. Make sure that the washer has not been damaged during the transportation process. If it has been damaged, contact the retailer and do not proceed any further with the installation process.

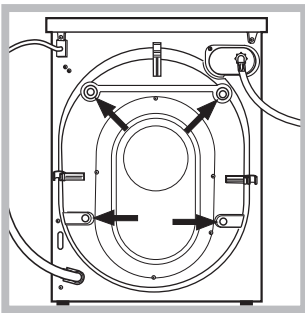

3. Remove the 4 protective screws (used during transportation) and the rubber washer with the corresponding spacer, located on the rear part of the appliance (see figure).

4. Close off the holes using the plastic plugs provided.
5. Keep all the parts in a safe place: you will need them again if the washer needs to be moved to another location.

! Packaging materials should not be used as toys for children.

Levelling

1. Install the washer on a flat sturdy floor, without resting it up against walls, furniture cabinets or anything else.

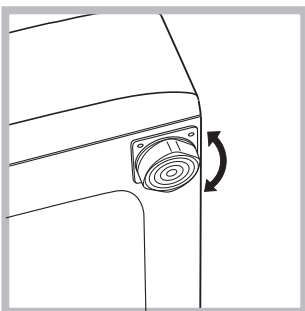

2. If the floor is not perfectly level, compensate for any unevenness by tightening or loosening the adjustable front feet (see figure); the angle of inclination, measured in relation to the worktop, must not exceed 2°.

Levelling the machine correctly will provide it with stability, help to avoid vibrations and excessive noise and prevent it from shifting while it is operating.

Minimum Installation Spacing

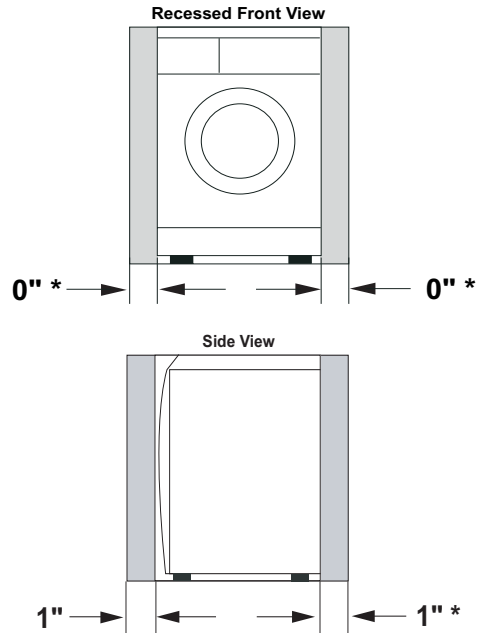

This appliance may be installed in a recessed area, closet or alcove. The installation spacing is in inches and is the minimum acceptable.

*Additional spacing should be considered for easy installation, servicing and compliance with local codes and ordinances. Installations must conform with the minimum dimensions indicated.

Connecting Water Inlet

If the water pipes you will be connecting to are new or unused, run the water until clear to remove any debris that could clog the water valve screens or valves before connecting the machine. NOTE: Supply shut-off valves should be easily accessible.



Important: Water pressure MUST range within the values indicated on the "Technical Data" chart.

1. Screw the cold water fill hose (**C** blue connector) onto the cold water supply until tight.

2. Turn on the cold water supply and check for leaks, tighten if necessary.

3. Screw the hot water fill hose (**H** red connector) onto the hot water supply until tight.

4. Turn on the hot water supply and check for leaks, tighten if necessary.

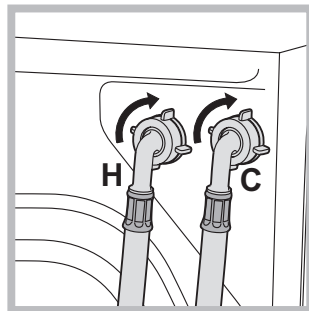

Important: Do not use excessive force. Damage to the couplings can result. The couplings should be tightened by hand; a tool should only be used if a leak occurs.

Drainage

- **Standpipe Diameter/Capacity** - Needs a 1 1/4" minimum diameter standpipe with a minimum carry-away capacity of 7 gallons per minute.
- **Top of Standpipe** - Must be between 25" - 34" high from the bottom of the machine.
- **Outlet End of Drain Hose (provided with the unit)** - Must be at least 20" above the bottom of the washer-dryer. An air break must be available at the standpipe to avoid siphoning. No more than 6" of the drain hose should be inserted into the drain pipe to prevent siphoning.

Connecting the drain hose

It is possible for the water to be discharged into a sink, standpipe or drainpipe, but an air break must be available at a min. 20" height to prevent the machine from siphoning (Fig. 6).

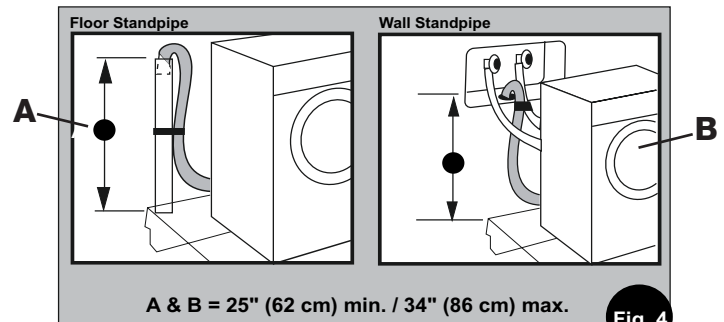

Fig. 4

Standpipe Drain System - Installations require a minimum 1 1/4" (3.2 cm) diameter standpipe with a minimum carry away capacity of 7 gallons (26 liters) per minute. Wall or Floor Standpipe Drain System - The top of the standpipe must be between 25" (62 cm) - 34" (86 cm) from the bottom of the washer (Fig. 4).

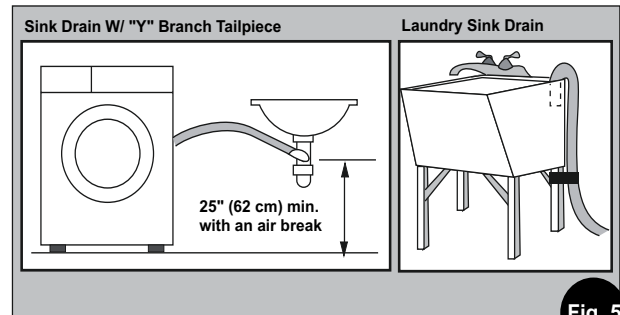

Fig. 5

Sink Drainpipe System - Entry into the sink drain system must be above the trap (Fig. 5). When routing the drain hose through cabinets or walls, use a protective material such as electrical or duct tape to cover sharp edges that could damage the drain hose. Use a suitable clamp to secure the drain hose to the "Y" branch or the disposer. With a sink drainpipe system, you may connect directly:

- 1) to a disposer by following the manufacturers attachment method.
- 2) directly to a "Y" branch tail piece (available at most hardware stores).



Important: Make sure that the drain hose is not kinked and that water flow is not restricted.

- 3) Through the floor to a separate trap. The trap must be vented to prevent siphoning. To provide proper venting, install an Air Gap Kit (available at most hardware stores).
- 4) To the faucet using a Faucet Adapter Kit (available separately).

- Use a U-Clamp (provided in your accessories packet) or suitable item to secure the outlet end of the drain hose (pre-installed on the back of your machine).

- Insert the outlet end of the drain hose into the standpipe, wall or floor drain (Fig. 6). NOTE: The outlet end of the drain hose MUST be at least 20" (50 cm) above the base of the machine. No more than 6" of the drain hose should be inserted into the drain pipe to prevent siphoning.
- Use a strap, cable tie, or similar item to hold the hose or the U-Clamp in place.

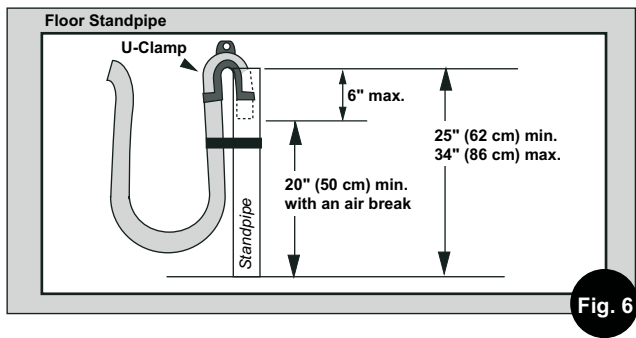

Fig. 6

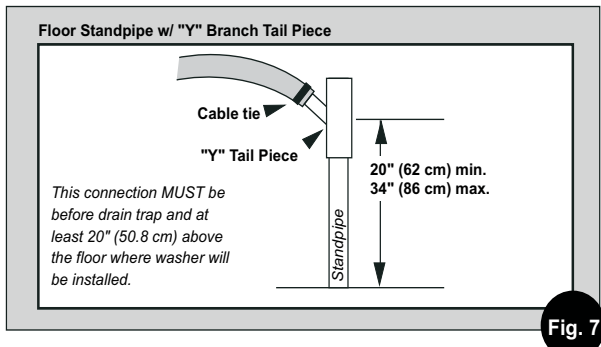
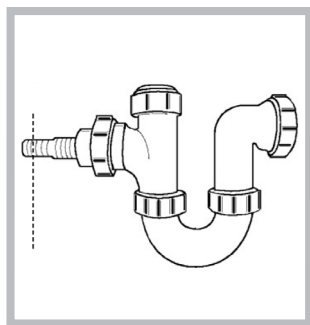
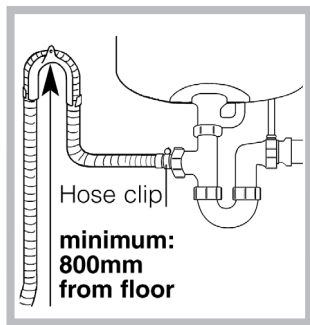

Fig. 7

Under Sink Method



1. Cut the blocked end of the under sink drainage unit.





2. Fix the hooked end support a minimum of 620 mm from the floor.

3. Use a hose clip clamp to securely attach the grey drainage hose end to the under sink drainage unit using a hose clamp

Electrical

- Machine Voltage/Amperage - 120V, 60 Hz, 4 Amp.
- Connection - 3-prong plug with 6' cord is provided with the machine.
- Circuit/Protector - 3-wire single phase, 120V, 60 Hz, AC, on a separate 15 Amp circuit.

Technical Information

Technical data	
Model	ARXL 129 W SP
Dimensions	width: 23.4" (59.5 cm) height: 33.24" - 33.75" (84.5 - 85.7 cm) depth: 22" (55.9 cm)
Weight	148 lbs
Minimum Installation Clearances	Sides: 0" Front / Back: 1"
Capacity	Washing: 2 to 15 lbs. (1 to 7 kg)
Electrical connections	Voltage: 120Volts, 4 A, 60 Hz
Water connections	Max. Pressure: 0.69 MPa (6.9 bar), 100 psi Min. Pressure: 0.05 MPa (0.5 bar), 7.2 psi
Max. Spin speed	up to 1200 RPM
Indesit Company offers their customers products with the ENERGY STAR Label. 	
This appliance was tested by UL and conforms with both Canadian and U.S. UL safety requirements and displays their Mark. 	

Description of the washing machine and starting a wash cycle

NA

Control panel

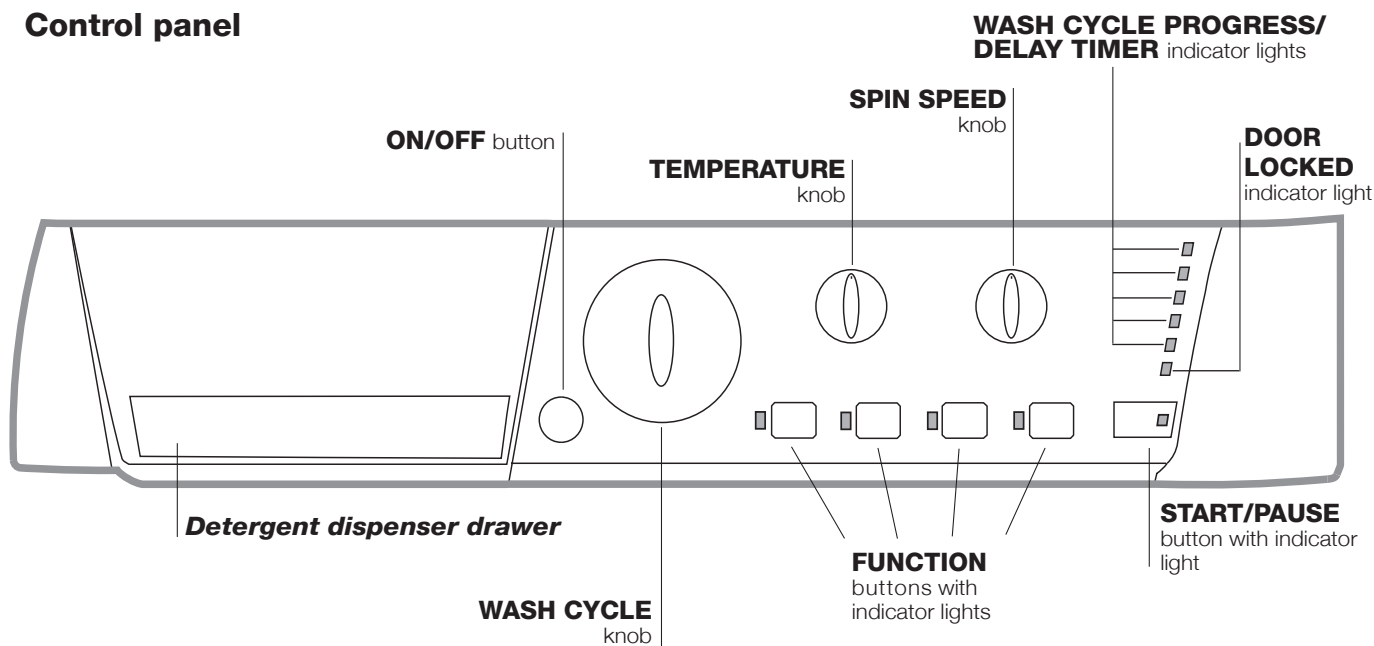

WARNING: To reduce the risk of fire, electric shock, or injury to persons, read the **IMPORTANT SAFETY INSTRUCTIONS** before operating this appliance.

Detergent dispenser drawer: used to dispense detergents and washing additives (see “Detergents and laundry”).

ON/OFF button: switches the washing machine on and off.

WASH CYCLE knob: programmes the wash cycles. During the wash cycle, the knob does not move.

FUNCTION buttons with indicator light: used to select the available functions. The indicator light corresponding to the selected function will remain lit.

TEMPERATURE knob: sets the temperature or the cold wash cycle (see “Personalization”).

The wash temperatures selections are uniformly distributed.

SPIN SPEED knob: sets the spin speed or exclude the spin cycle completely (see “Personalization”).

WASH CYCLE PROGRESS/DELAY TIMER indicator lights: used to monitor the progress of the wash cycle. The illuminated indicator light shows which phase is in progress.

If the Delay Timer function has been set, the time remaining until the wash cycle starts will be indicated (see next page).

DOOR LOCKED indicator light: indicates whether the door may be opened or not (see next page).

START/PAUSE button with indicator light: starts or temporarily interrupts the wash cycles.

NOTE: To pause the wash cycle in progress, press this button; the corresponding indicator light will flash orange, while the indicator light for the current wash cycle phase will remain lit in a fixed manner. If the **DOOR LOCKED** indicator light is switched off, the door may be opened. To start the wash cycle from the point at which it was interrupted, press this button again.

Indicator lights

The indicator lights provide important information. This is what they can tell you:

Delayed start

If the DELAY TIMER function has been activated (see "Personalization"), after the wash cycle has been started the indicator light corresponding to the selected delay period will begin to flash:



As time passes, the remaining delay will be displayed and the corresponding indicator light will flash:



Once the set delay has elapsed, the flashing indicator light will switch off and the selected wash cycle will begin.

Wash cycle phase indicator lights

Once the desired wash cycle has been selected and has begun, the indicator lights switch on one by one to indicate which phase of the cycle is currently in progress.



Function buttons and corresponding indicator lights

When a function is selected, the corresponding indicator light will illuminate.

If the selected function is not compatible with the programmed wash cycle, the corresponding indicator light will flash and the function will not be activated.

If a function which is incompatible with another function selected previously, only the most recent selection will remain active.

Door locked indicator light

If this indicator light is on, the appliance door is locked to prevent it from being opened accidentally; to avoid any damage, wait for the indicator light to switch off before you open the appliance door.

NOTE: If the DELAY TIMER function is activated, the door cannot be opened; pause the machine by pressing the START/PAUSE button if you wish to open it.

! If the START/PAUSE indicator light (orange) flashes rapidly at the same time as the function indicator light, this indicates a problem has occurred (see "Troubleshooting").

Starting a wash cycle

1. Switch the washing machine on by pressing the ON/OFF button. All indicator lights will switch on for a few seconds, then they will switch off and the START/PAUSE indicator light will pulse.
2. Load the laundry and close the door.
3. Set the WASH CYCLE knob to the desired programme.
4. Set the washing temperature (see "Personalization").
5. Set the spin speed (see "Personalization").
6. Measure out the detergent and washing additives (see "Detergents and laundry").
7. Select the desired functions.
8. Start the wash cycle by pressing the START/PAUSE button and the corresponding indicator light will remain lit in a fixed manner, in green.

To cancel the set wash cycle, pause the machine by pressing the START/PAUSE button and select a new cycle.

9. At the end of the wash cycle the **END** indicator light will switch on. The **DOOR LOCKED** indicator light will switch off, indicating that the door may be opened. Take out your laundry and leave the appliance door ajar to make sure the drum dries completely.

Switch the washing machine off by pressing the ON/OFF button.

Table of wash cycles

Wash cycles	Description of the wash cycle	Max. temp. (°C)	Max. speed (rpm)	Detergents			Max load (lb)	Cycle duration
				Bleach	Wash	Fabric softener		
Essentials cycles								
1	Cottons Regular: Heavily soiled whites and resistant colours.	Hot	Max	-	●	●	Max	82
2	Cottons Colored: Lightly soiled whites and delicate colours.	Warm	Max	-	●	●	Max	81
3	Permanent Press: Normally soiled synthetics or permanent press labelled garments.	Warm	800	-	●	●	6.6	76
4	Quick Wash	Warm	Max	-	●	●	2.20	60
5	Mixed Load 30 min.: To refresh lightly soiled garments quickly (not suitable for wool, silk and clothes which require washing by hand).	Warm	800	-	●	●	6.6	30
Special wash cycles								
6	Bright White: Heavily soiled whites and resistant colours.	Warm	Max	●	●	●	Max	95
7	Jeans	Hot	800	-	●	●	6.6	60
8	Active Wear	Warm	600	-	●	●	6.6	63
9	Infant Wear: Heavily soiled delicate colours	Warm	800	-	●	●	4.4	118
10	Lightly Soiled 15 min.: To refresh lightly soiled garments quickly (not suitable for wool, silk and clothes which require washing by hand)	Warm	800	-	●	●	3.30	15
Delicates								
11	Delicate: Lightly soiled delicates colours.	Warm	800	-	●	●	6.6	64
12	Silk/Curtains	Warm	0	-	●	●	2.20	55
13	Wool: for wool, cashmere, etc.	Warm	600	-	●	●	3.30	55
Partials wash cycles								
A	Rinse	-	Max	-	-	●	Max	36
B	Spin	-	Max	-	-	-	Max	16
C	Drain	-	-	-	-	-	Max	2

Special wash cycles

Permanent press (wash cycle 3) this cycle has less mechanical agitation and spinning speed designed to reduce wrinkles.

Mixed Load (wash cycle 5) this wash cycle was designed to wash lightly soiled garments quickly: it lasts just 30 minutes and therefore saves both energy and time. By selecting this wash cycle (5 at WARM temperature), it is possible to wash different fabrics together (except for wool and silk items), with a maximum load of 6.6 lb - (3 kg).

Bright White (wash cycle 6) Use this cycle when bleaching with hypochlorite based products.

Pour the bleach, the detergent and the additives into the relevant compartments (see paragraph entitled "Detergent dispenser drawer").

Active wear (wash cycle 8) is for washing lightly soiled sports clothing fabrics (tracksuits, shorts, etc.); for best results, we recommend not exceeding the maximum load indicated in the "Table of wash cycles".

Infant Wear (wash cycle 9). This wash cycle can be used to remove the soiling typically caused by babies, while ensuring that all detergent is removed from nappies in order to prevent the delicate skin of babies from suffering allergies. The cycle has been designed to reduce the amount of bacteria by using a greater quantity of water and optimising the effect of special disinfecting additives added to the detergent.

At the end of the wash cycle, the machine will slowly rotate the drum to prevent the formation of creases; to end the cycle press the START/PAUSE button.

Lightly Soiled 15 min. (wash cycle 10) this wash cycle was designed to wash lightly soiled garments quickly: it lasts just 15 minutes and therefore saves both energy and time. By selecting this wash cycle (10 at WARM temperature), it is possible to wash different fabrics together (except for wool and silk items), with a maximum load of 3.30 lb - (1.5 kg). For this cycle we recommend pretreating stains, shirt necks and wrists with specific antistain products.

Personalization

NA

Setting the temperature

By pressing the **TEMPERATURE** button to set the wash temperature. (See **Table of wash cycles**) Wash temperature can be set selecting , “Cold”, “Warm”, “Hot” or 2 in-between positions which correspond to intermediate levels of water temperature (example: the position between “cold” and “warm” is lukewarm). See below for the indication in °C and °F for each temperature position.

The available selections are:

-  Tap water
- **Cold** 15 °C/ 59 °F
- 20 °C/ 68 °F
- 25 °C/ 77 °F
- **Warm** 30 °C/ 86 °F
- 35 °C/ 95 °F
- 40 °C/ 104 °F
- **Hot** 57 °C / 134 °F

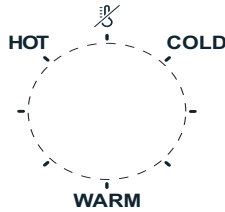

Setting the spin speed

Turn the SPIN SPEED knob to set the spin speed for the selected wash cycle.

The maximum spin speeds available for each wash cycle are as follows:

Wash cycles	Maximum spin speed
Cottons	1200 rpm only
Synthetics	800 rpm
Wool	600 rpm
Silk	drain only

The spin speed may be lowered, or the spin cycle can be excluded altogether by selecting the symbol .

The washing machine will automatically prevent you from selecting a spin speed which is higher than the maximum speed set for each wash cycle.

Note: For the first two Programmes (Cottons Regular and Cottons Colored) the garments will be spun at maximum speed. This allows to get the most from the spinning phase and reduce time and energy needed for the drying.

Functions

The various wash functions available with this washing machine will help to achieve the desired results, every time.

To activate the functions:

1. Press the button corresponding to the desired function;
2. the function is enabled when the corresponding indicator light is illuminated.

Note: If the indicator light flashes rapidly, this signals that this particular function may not be selected in conjunction with the selected wash cycle.

Delay timer

This timer delays the start time of the wash cycle by up to 12 hours.

Press the button repeatedly until the indicator light corresponding to the desired delay time switches on. The fifth time the button is pressed, the function will be disabled.

NOTE: Once you have pressed the START/PAUSE button, the delay time may only be decreased if you wish to modify it.

! This option is enabled with all programmes.

Reduced Wrinkles

By selecting this function, the wash and spin cycles will be modified in order to reduce the formation of creases. At the end of the cycle the washing machine will perform slow rotations of the drum; the REDUCED WRINKLES indicator light will switch on and the START/PAUSE indicator light will flash in an orange colour and the phase **END** will remain lit in a fixed manner.

To end the cycle, press the START/PAUSE button or the REDUCED WRINKLES button.

For the **Silk/Curtains** cycle, the machine will end the cycle while the laundry is soaking and the REDUCED WRINKLES indicator light will flash. To drain the water so that the laundry may be removed, press the START/PAUSE button or the REDUCED WRINKLES button.

! It may not be used with the 5, 8, 9, 10, 13, B, C.

 **Extra rinse**

By selecting this function, the efficiency of the rinse is increased and optimal detergent removal is guaranteed. It is particularly useful for sensitive skin.

! This function may not be used in conjunction with wash cycles 5, 10, B, C.

 **Super Wash**

Because a greater quantity of water is used in the initial phase of the cycle, and because of the increased cycle duration, this function offers a high-performance wash.

! This function may not be used in conjunction with wash cycles 4, 5, 7, 10, 12, 13, A, B, C.

Detergents and laundry

NA

Detergent dispenser drawer

Good washing results also depend on the correct dose of detergent: adding too much detergent will not necessarily result in a more efficient wash, and may in fact cause build up on the inside of your appliance and contribute to environmental pollution.

! Do not use hand washing detergents because these create too much foam.

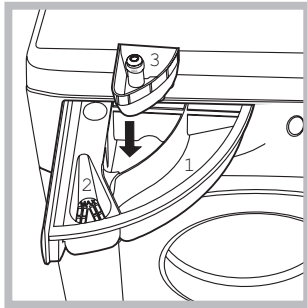

Open the detergent dispenser drawer and pour in the detergent or washing additive, as follows.

compartment 1: Detergent for the wash cycle (powder or liquid)

Liquid detergent should only be poured in immediately prior to the start of wash cycle.

compartment 2: Additives (fabric softeners, etc.)

The fabric softener should not overflow the grid.

extra compartment 3: Bleach

Bleach cycle

Bleaching may only be performed in conjunction with wash cycles **6**. Pour the bleach into extra compartment **3**; pour the detergent and softener into the corresponding compartments, then select one of the abovementioned wash cycles.

This option is recommended only for very soiled cotton garments.

Preparing the laundry

- Divide the laundry according to:
 - the type of fabric/the symbol on the label.
 - the colours: separate coloured garments from whites
- Empty all garment pockets and check the buttons.
- Do not exceed the listed values, which refer to the weight of the laundry when dry:
 - Durable fabrics: max. 15 lb - (7 kg)
 - Synthetic fabrics: max. 6.6 lb - (3 kg)
 - Delicate fabrics: max. 4.4 lb - (2 kg)
 - Wool: max. 3.30 lb - (1,5 kg)

How much does your laundry weigh?

- 1 sheet 14-17 oz - (400-500 g)
- 1 pillow case 5-7 oz - (150-200 g)
- 1 tablecloth 14-17 oz - (400-500 g)
- 1 bathrobe 31-42 oz - (900-1200 g)
- 1 towel 5-8 oz - (150-250 g)

Garments requiring special care

Jeans: Turn garments inside-out before washing. Use programme **7**.

Silk: use special wash cycle **12** to wash all silk garments. We recommend the use of special detergent which has been designed to wash delicate clothes.

Curtains: fold curtains and place them in a pillow case or mesh bag. Use wash cycle **12**.

Wool: Ariston is the only washer manufacturer to have been awarded the prestigious Woolmark Platinum Care endorsement (M.0508) by the Woolmark Company, which means that all woollen garments may be washed in the washer, even those which state "hand wash only"  on the label. Wash cycle **13** therefore offers complete peace of mind when washing woollen garments in the washer (max. load 3.30 lb - 1,5 kg) and guarantees optimal performance.

Load balancing system

Before every spin cycle, to avoid excessive vibrations and to distribute the load in a uniform manner, the drum rotates continuously at a speed which is slightly greater than the washing rotation speed. If, after several attempts, the load is not balanced correctly, the machine spins at a reduced spin speed. If the load is excessively unbalanced, the washer performs the distribution process instead of spinning. To encourage improved load distribution and balance, we recommend small and large garments are mixed in the load.

Helpful Hints

Your washer features three different speeds during the wash cycle. During the Cotton cycle the drum spins at 1,200 or 800 rpm. During Permanent Press the drum spins at 850 rpm. During delicates, the drum spins at 500 rpm.

Use Liquid Fabric Softener. Fill the softener compartment up to the level marked. Using fabric softener fluffs out clothes immediately after the wash cycle. This helps speed drying time and reduce wrinkles.

Use Low sudsing Detergent. This is recommended for all front loading washers. It ensures there is no over sudsing, which may reduce the performance of your machine. Splendide All-Natural Premium Laundry Powder (Part No. 1005)

When sorting laundry always take into consideration the quantity and type of fabric contained in the load. Highly absorbent fabrics such as those used in towels or jeans will absorb more water and become very heavy when saturated. If you notice that your clothes are taking longer than usual to dry may be overloading the machine, or washing too many highly absorbent articles for a single load.

Cutting off the water and electricity supplies

- Turn off the water tap after every wash cycle. This will limit wear on the hydraulic system inside the washing machine and help to prevent leaks.
- Unplug the washing machine when cleaning it and during all maintenance work.

Cleaning the washing machine

The outer parts and rubber components of the appliance can be cleaned using a soft cloth soaked in lukewarm soapy water. Do not use solvents or abrasives.

Cleaning the detergent dispenser drawer

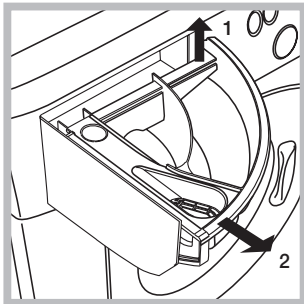

Remove the dispenser by raising it and pulling it out (see figure). Wash it under running water; this operation should be repeated frequently.

Caring for the door and drum of your appliance

- Always leave the porthole door ajar in order to prevent unpleasant odours from forming.

Cleaning the pump

The washing machine is fitted with a self-cleaning pump which does not require any maintenance. Sometimes, small items (such as coins or buttons) may fall into the pre-chamber which protects the pump, situated in its bottom part.

! Make sure the wash cycle has finished and unplug the appliance.

To access the pre-chamber:

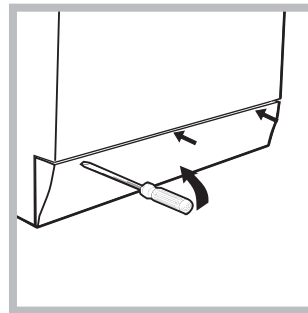

1. using a screwdriver, remove the cover panel on the lower front part of the washing machine (see figure);

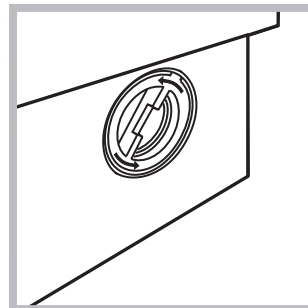

2. unscrew the lid by rotating it anti-clockwise (see figure); a little water may trickle out. This is perfectly normal;

3. clean the inside thoroughly;
4. screw the lid back on;
5. reposition the panel, making sure the hooks are securely in place before you push it onto the appliance.

Checking the water inlet hose

Check the inlet hose at least once a year. If there are any cracks, it should be replaced immediately: during the wash cycles, water pressure is very strong and a cracked hose could easily split open.

! Never use second-hand hoses.

Troubleshooting

NA

Your washing machine could fail to work. Before contacting the Technical Assistance Centre (see "Assistance"), make sure that the problem cannot be not solved easily using the following list.

Problem:

Possible causes / Solutions:

The washing machine does not switch on.

- The appliance is not plugged into the socket fully, or is not making contact.
- There is no power in the house.

The wash cycle does not start.

- The washing machine door is not closed properly.
- The ON/OFF button has not been pressed.
- The START/PAUSE button has not been pressed.
- The water tap has not been opened.
- A delayed start has been set (see "Personalization").

The washing machine does not take in water (the indicator light for the first wash cycle stage flashes rapidly).

- The water inlet hose is not connected to the tap.
- The hose is bent.
- The water tap has not been opened.
- There is no water supply in the house.
- The pressure is too low.
- The START/PAUSE button has not been pressed.

The washing machine continuously takes in and drains water.

- The drain hose is not fitted at a height between 65 and 100 cm from the floor (see "Installation").
- The free end of the hose is under water (see "Installation").
- The wall drainage system is not fitted with a breather pipe.

If the problem persists even after these checks, turn off the water tap, switch the appliance off and contact the Assistance Service. If the dwelling is on one of the upper floors of a building, there may be problems relating to water drainage, causing the washing machine to fill with water and drain continuously. Special anti-draining valves are available in shops and help to avoid this inconvenience.

The washing machine does not drain or spin.

- The wash cycle does not include draining: some wash cycles require the drain phase to be started manually.
- The REDUCED WRINKLES function has been activated: To complete the wash cycle, press the START/PAUSE button ("Personalization").
- The drain hose is bent (see "Installation").
- The drainage duct is clogged.

The washing machine vibrates a lot during the spin cycle.

- The drum was not unlocked correctly during installation (see "Installation").
- The washing machine is not level (see "Installation").
- The washing machine is trapped between cabinets and walls (see "Installation").

The washing machine leaks.

- The water inlet hose is not screwed on properly (see "Installation").
- The detergent dispenser drawer is blocked (for cleaning instructions, see "Care and maintenance").
- The drain hose is not fixed properly (see "Installation").

The START/PAUSE indicator light (orange) and the function indicator lights flash rapidly.

- Switch off the machine and unplug it, wait for approximately 1 minute and then switch it back on again.
If the problem persists, contact the Technical Assistance Service.

There is too much foam.

- The detergent is not suitable for machine washing (it should display the text "for washing machines" or "hand and machine wash", or the like).
- Too much detergent was used.

Before calling for Assistance:

- Check whether you can solve the problem alone (see “Troubleshooting”);
- Restart the programme to check whether the problem has been solved;
- If this is not the case, contact an authorised Technical Assistance Centre using the telephone number provided on the guarantee certificate.

! Always request the assistance of authorised technicians.

Have the following information at hand:

- the type of problem;
- the appliance model (Mod.);
- the serial number (S/N).

This information can be found on the data plate applied to the rear of the washing machine, and can also be found on the front of the appliance by opening the door.

If You Have	You'll Need to Buy
No access to Hot/Cold water hookups	Splendide Faucet Adapter kit, Part No. 154187104A (8ft , 2.4m)
Water damage Concerns	Splendide Drain-A-Way™ Pan , Part No. PI-22, PI-24 (or similar)
Floor drain	Siphon break kit (sold at most hardware stores)
Disposer drain	“Y” connector (sold at most hardware stores)
Shifting Concerns (RV and Marine Installations)	Splendide SecureFit™ installation Brackets , Part No. MK01. Keeps washer in place during travel to prevent: <ul style="list-style-type: none"> • Kinked inlet hoses • Disconnected dryer vent hoses • Crushed dryer vent hose • Blocked dispenser drawer • Knobs rubbing against closed doors • Scuffed cabinet woodwork

**All Splendide parts are available
direct from Westland Sales: 1-800-356-0766**

Warranty

ARISTON ONE-YEAR LIMITED WARRANTY (USA & CANADA ONLY)

NA

WHO IS COVERED BY THIS WARRANTY

This limited one-year warranty (“Warranty”) is given only to the original end-use/retail purchaser (the “First Using Purchaser”) of the accompanying Ariston product(s) (the “Ariston Product”).

If you purchased this Ariston Product from someone other than an authorized Ariston reseller/dealer in the United States or Canada, or if the Ariston Product was used (including but not limited to floor models or refurbished products) prior to your purchase, then you are not the First Using Purchaser and the Ariston Product that you purchased is not covered by this Warranty. This Warranty is not transferable.

WHAT IS COVERED BY THIS WARRANTY

Ariston will repair or replace any part of the Ariston Product which fails due to a defect in materials or workmanship when used under normal home-use conditions. Ariston will also provide, free of charge, all labor and related services to repair or replace the defective part.

This Warranty applies only to Ariston Products purchased and used in the United States or Canada. Subject to the exclusions below, for Ariston Products purchased in, but used outside, the United States or Canada, this Warranty covers only warranty service within the United States or Canada (and does not include shipping outside the United States or Canada).

LENGTH OF THE WARRANTY

This Warranty runs for a period of one (1) year from the date of the original purchase by the First Using Purchaser. Please note that a copy of your original purchase receipt showing the purchase date and the vendor’s name and address are required to obtain service under this Warranty. For the purposes of determining the applicable warranty period, please note that any and all replaced or repaired parts shall assume the identity of the original.

WHAT IS NOT COVERED BY THE WARRANTY (EXCLUSIONS)

This Warranty does not cover:

1. Improper installation, delivery, maintenance and/or improper operation of the Ariston Product.
2. Damage caused if the Ariston Product has not been used in compliance with the electricity or gas supply specifications printed on the rating plate.
3. Failure of or damage to the Ariston Product if it is altered, abused, misused, or used for other than the intended purpose, or if it is used commercially.
4. Service trips to your home to provide instructions on the use of your Ariston Product.

5. Replacement of house fuses or correction of the plumbing or electric wiring in your home.
 6. Damage caused by neglect, accident, fire, floods or acts of God.
 7. Physical Damage to the appearance of your Ariston Product including, without limitation, scratches, rust, dents, warping, peeling and the like.
 8. Damage caused by transportation.
 9. Replacement of any consumable or degradable item or accessory including, but not limited to: plugs, cables, batteries, light bulbs, fluorescent tubes and starters, covers and filters, or replacement of any removable parts made of glass or plastic.
 10. Damage caused after delivery.
 11. Water damage of any kind.
 12. An Ariston Product not accessible to provide required service.
 13. Problems arising from other than defects in materials or workmanship.
 14. Travel time when installed in a recreational vehicle or marine application.
- This Warranty is void if the Ariston Product is altered, serviced, maintained, dismantled, or otherwise interfered with by any person who is not authorized by Ariston.
15. Non-standard labor when installed in a marine application.
 16. Water leaks of any kind.

TO THE EXTENT PERMITTED BY LAW, THIS WARRANTY IS IN LIEU OF ALL OTHER WARRANTIES, WRITTEN OR ORAL, WHETHER EXPRESSED BY AFFIRMATION, PROMISE, DESCRIPTION, DRAWING, MODEL OR SAMPLE. ANY AND ALL WARRANTIES OTHER THAN THIS ONE, WHETHER EXPRESS OR IMPLIED, INCLUDING IMPLIED WARRANTIES OF MERCHANTABILITY AND FITNESS FOR A PARTICULAR PURPOSE, ARE HEREBY DISCLAIMED. IMPLIED WARRANTIES INCLUDING, BUT NOT LIMITED TO, THE IMPLIED WARRANTIES OF MERCHANTABILITY AND FITNESS THAT CANNOT BE EXCLUDED BY LAW, SHALL BE LIMITED TO THE SAME DURATION AS THIS WARRANTY. EXCEPT FOR THAT REPAIR OR REPLACEMENT AS DESCRIBED ABOVE, ARISTON SHALL NOT BE LIABLE FOR ANY DIRECT, INDIRECT, INCIDENTAL OR CONSEQUENTIAL DAMAGES OR SPECIFIC RELIEF.

Some States and Provinces do not allow the exclusion or limitation of incidental or consequential damages and/or implied warranties, so the above limitations or exclusions may not apply to you. This Warranty gives you specific legal rights and you may also have other legal rights which vary from State to State or Province to Province.

WHAT YOU SHOULD DO TO OBTAIN WARRANTY SERVICE

All repairs or warranty service must be provided by Ariston or an Authorized Ariston Service Center.

To schedule warranty service please call 1-877-356-0766, email service@aristonamerica.com. Please remember to provide us with your Ariston Product's model number and serial number.

Please note that a copy of your original purchase receipt showing the purchase date and the vendor's name and address are required to obtain service under this Warranty. If the Ariston Product is located in an area where service by an Authorized Ariston Service Center is not available, you may be responsible for a trip charge or you may be required to bring the Ariston Product to an Authorized Ariston Service Center for service.

The foregoing are your sole (i.e., only) and exclusive remedies under this Warranty. This Warranty is the only warranty that Ariston is giving for this Ariston Product. This Warranty replaces all other agreements and understandings that you may have with Ariston or its representatives.

NA